

財源机械五金贸易
CHYE GUAN TRADING

No. 82 & 84, Jalan Suria 2, Taman Malim Jaya, 75250 Melaka.
Tel: 06- 3363480, 06-3363482 Fax: 06-3363480
Email: chyeguan82@gmail.com

LIFTING TOOLS

SHUANG GE [HS TYPE] CHAIN BLOCK

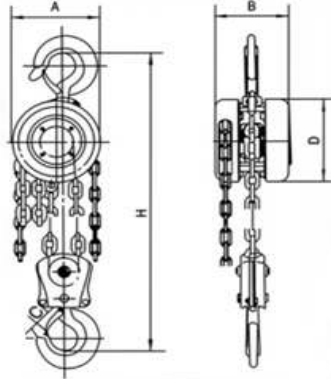

Model	Main Dimension (mm)				Packing Size (cm)
	A	B	C	D	
HS 0.5	120	108	24	120	28x21x17
HS 1.0	142	122	28	142	30x24x18
HS 1.5	178	139	34	178	34x29x20
HS 2.0	142	122	34	142	33x28x19
HS 3.0	178	139	38	178	38x38x20
HS 5.0	210	162	48	210	45x39x24
HS 10	358	162	64	210	55x51x29
HS 20	580	189	82	210	70x46x75

Model	Capacity	Standard Lift	Running Test Load	Headroom (H Min. Range)	Load Chain		Effort Required	Weight
					Column	Diameter		
HS 0.5	0.5 ton	2.5 m 3 m	0.75 ton	240 mm	1	6 x 18 mm	221 N	8 kg
HS 1.0	1.0 ton	3 m 5 m	1.50 ton	270 mm	1	6 x 18 mm	304 N	10 kg
HS 1.5	1.5 ton	3 m 5 m	2.25 ton	347 mm	1	8 x 24 mm	343 N	16 kg
HS 2.0	2.0 ton	3 m 5 m	3.00 ton	380 mm	2	6 x 18 mm	314 N	14 kg
HS 3.0	3.0 ton	3 m 5 m	4.50 ton	470 mm	2	8 x 24 mm	343 N	24 kg
HS 5.0	5.0 ton	3 m 5 m	6.25 ton	600 mm	2	10 x 30 mm	381 N	36 kg
HS 10	10 ton	5 m	12.50 ton	700 mm	4	10 x 30 mm	392 N	68 kg
HS 20	20 ton	5 m	28.00 ton	1000 mm	8	10 x 30 mm	392 N	155 kg

SHUANG GE [HSH TYPE] LEVER BLOCK

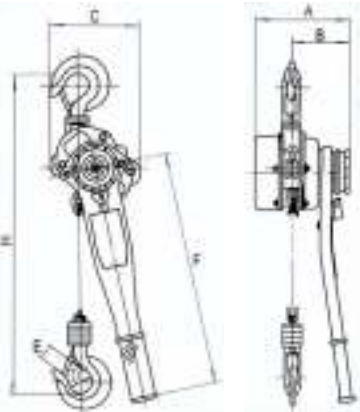

Model	Main Dimensions (mm)						Packing Size (mm)
	A	B	C	D	E	F	
HSH 0.75	139	84	153	38	28	280	382x167x162
HSH 1.50	174	108	160	45	34	410	517x197x177
HSH 3	200	115	186	50	38	410	577x247x217
HSH 6	200	115	230	65	45	410	577x247x217

Model	Capacity	Standard Lift	Running Test Load	Headroom (H Min. Range)	Load Chain		Effort Required	Weight
					Column	Diameter		
HSH 0.75	0.75 ton	1.5 m	1.125 ton	303 mm	1	6.0 x 18 mm	196 N	7 kg
HSH 1.50	1.50 ton	1.5 m	2.25 ton	365 mm	1	7.1 x 18 mm	206 N	11 kg
HSH 3	3 ton	1.5 m	4.50 ton	485 mm	1	10 x 30 mm	324 N	20 kg
HSH 6	6 ton	1.5 m	7.50 ton	600 mm	2	10 x 30 mm	343 N	30 kg

LIFTING TOOLS

SHUANG GE GEARED TROLLEY

[GCL-AK]

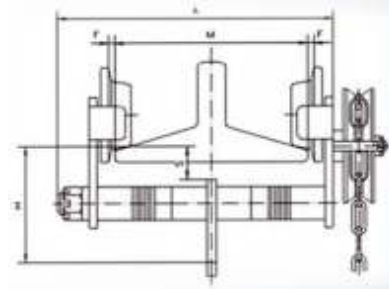
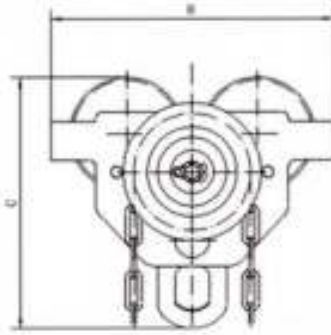

SHUANG GE PLAIN TROLLEY

[GCT-AK]

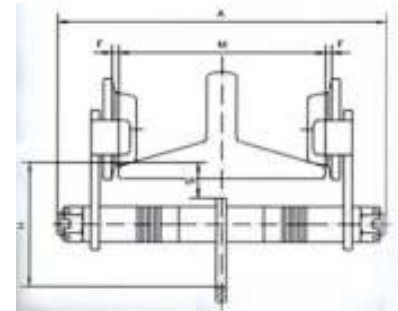
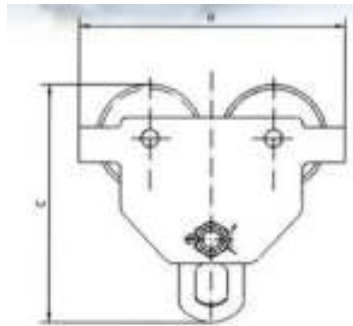

GEARED TROLLEY						PLAIN TROLLEY				
10	5	3	2	1	Capacity (ton)	1	2	3	5	10
122.58	61.29	44.13	29.42	14.71	Test Load (KN)	14.71	29.42	44.13	61.29	122.58
2.0	1.3	1.2	1.0	0.9	Min. Radius of Curve (m)	0.9	1.0	1.2	1.3	2.0
423	373	358	350	336	A	A	310	325	345	408
424	362	322	268	236	B	B	236	268	322	424
396	342	295	247	208	C	C	208	247	295	396
190	185	157	134	111	H	H	111	134	157	190
2-3.5	2-3.5	2-3.5	1.5-3	1.5-3	F	F	1.5-3	1.5-3	1.5-3	1.5-3
40	36	32	30	28	S(≥)	S(≥)	28	30	32	40
124-203	114-203	100-203	88-203	64-203	I-Beam Width (mm)		64-203	88-203	100-203	114-203
88	42	28.5	18	13	Weight (kg)		9.5	14.5	24.5	78.8

財源机械五金贸易

CHYE GUAN TRADING

No. 82 & 84, Jalan Suria 2, Taman Malim Jaya, 75250 Melaka.

Tel: 06- 3363480, 06-3363482 Fax: 06-3363480

Email: chyeguan82@gmail.com

LIFTING TOOLS

SATO [HS-J] CHAIN BLOCK

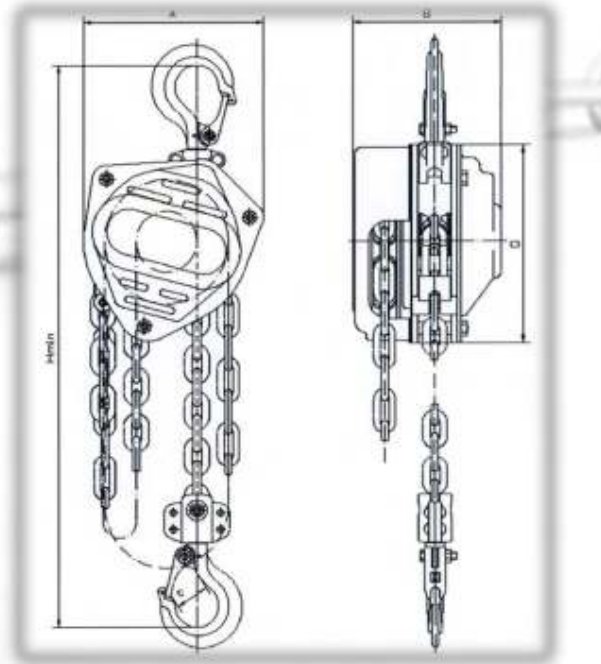

Model	Main Dimensions (mm)				Packing Size (cm)
	A	B	C	D	
HS-J 0.5	138	114	21.5	145	28x21x17
HS-J 1.0	164	124	27	182	30x24x18
HS-J 1.5	198	142	30	219	34x29x21
HS-J 2.0	164	124	30	182	33x28x19
HS-J 3.0	195	142	37	219	38x33x20
HS-J 5.0	228	167	46	252	45x39x24
HS-J 10	367	167	54	252	55x51x29

Model	Capacity	Standard Lift	Running Test Load	Headroom (H Min. Range)	Load Chain		Effort Required	Weight
					Column	Diameter		
HS-J 0.5	0.5 ton	3 m	0.75 ton	271 mm	1	6 x 18 mm	221 N	9 kg
		5 m						
HS-J 1.0	1.0 ton	3 m	1.50 ton	400 mm	1	6 x 18 mm	304 N	11 kg
		5 m						
HS-J 1.5	1.5 ton	3 m	2.25 ton	453 mm	1	8 x 24 mm	343 N	17 kg
		5 m						
HS-J 2.0	2.0 ton	3 m	3.00 ton	420 mm	2	6 x 18 mm	314 N	15 kg
		5 m						
HS-J 3.0	3.0 ton	3 m	4.50 ton	620 mm	2	8 x 24 mm	343 N	24 kg
		5 m						
HS-J 5.0	5.0 ton	3 m	6.25 ton	704 mm	2	10 x 30 mm	382 N	39 kg
		5 m						
HS-J 10	10 ton	5 m	12.50 ton	720 mm	4	10 x 30 mm	392 N	72 kg

財源机械五金贸易

CHYE GUAN TRADING

No. 82 & 84, Jalan Suria 2, Taman Malim Jaya, 75250 Melaka.

Tel: 06- 3363480, 06-3363482 Fax: 06-3363480

Email: chyeguan82@gmail.com

LIFTING TOOLS

SATO [HSH TYPE] LEVER BLOCK

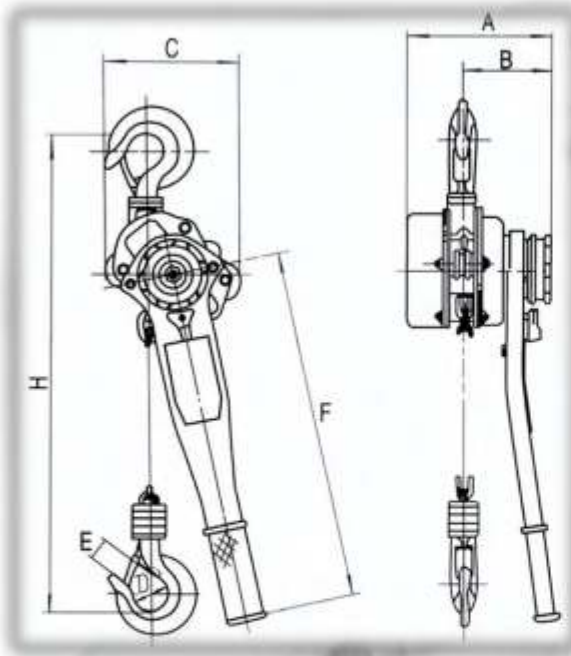

Model	Main Dimensions (mm)						Packing Size (mm)
	A	B	C	D	E	F	
HSH 0.75	155	95	135	37	30	285	355x140x165
HSH 1.50	180	105	155	45	36	370	465x155x190
HSH 3	215	130	200	50	40	410	510x190x215
HSH 6	215	130	200	64	50	410	530x220x215

Model	Capacity	Standard Lift	Running Test Load	Headroom (H min. range)	Load Chain		Effort Required	Weight
					Column	Diameter		
HSH 0.75	0.75 ton	1.5 m	11.0 Kn	320 mm	1	6 mm	140 N	7.7 kg
HSH 1.50	1.50 ton	1.5 m	22.5 Kn	380 mm	1	8 mm	240 N	11.8 kg
HSH 3	3 ton	1.5 m	37.5 Kn	480 mm	1	10 mm	320 N	21 kg
HSH 6	6 ton	1.5 m	75.0 Kn	600 mm	2	10 mm	340 N	32 kg

財源机械五金贸易

CHYE GUAN TRADING

No. 82 & 84, Jalan Suria 2, Taman Malim Jaya, 75250 Melaka.

Tel: 06- 3363480, 06-3363482 Fax: 06-3363480

Email: chyeguan82@gmail.com



LIFTING TOOLS

SATO GEARED TROLLEY

[KWD-III]

SATO PLAIN TROLLEY

[KWD-II]

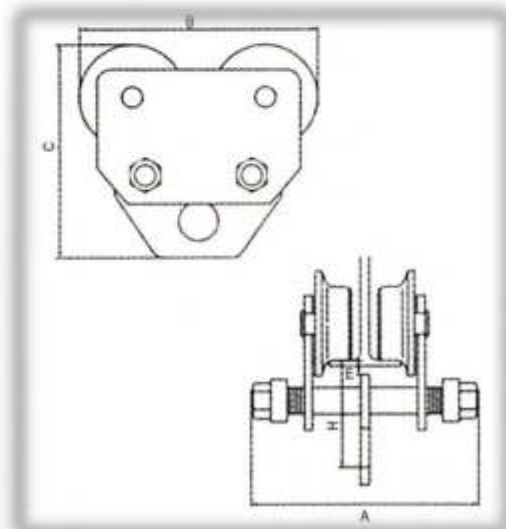
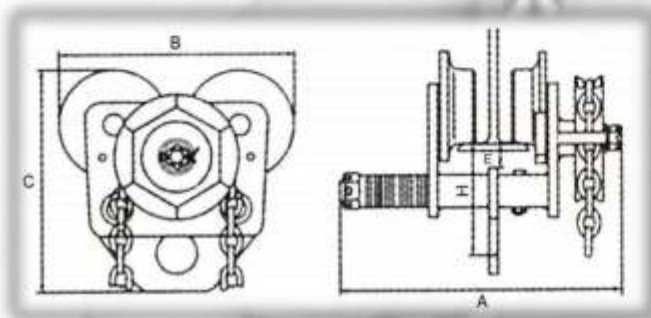

GEARED TROLLEY					PLAIN TROLLEY					
10	5	3	2	1	Capacity (ton)	1	2	3	5	10
122.58	61.29	44.13	29.42	14.71	Test Load (KN)	14.71	29.42	44.13	61.29	122.58
1.7	1.4	1.3	1.1	1.0	Min. Radius of Curve (m)	1.0	1.1	1.3	1.4	1.7
423	328	289	278	246	A	A	206	240	252	294
390	302	276	233	206	B	B	206	233	276	302
416	327	283	238	194	C	C	194	238	283	327
212	170	145	126	97	H	H	97	126	145	170
42	35	28	28	22	E	E	22	28	28	35
125-210	125-175	100-150	100-150	75-125	I-Beam Width (mm)	75-125	100-150	100-150	125-175	125-210
82.0	42.6	28.9	18.8	12.2	Net Weight (kg)	8.0	14.6	24.2	38.4	78.0

LIFTING TOOLS

ELECTRIC CHAIN HOIST

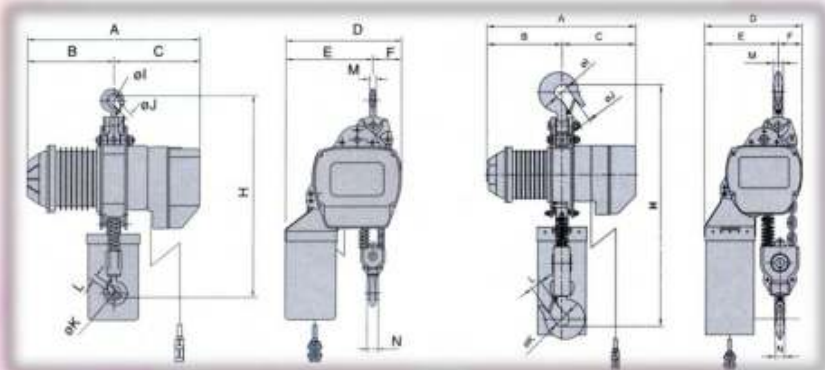

Capacity (ton)	Model	Dimensions (mm)												
		H	A	B	C	D	E	F	I	J	K	L	M	N
0.5	YSH,H,E,F-050	570	505	245	260	240	115	125	40	28	40	28	23	23
1	YSH,H,E,F-100	570	505	245	260	240	115	125	40	28	40	28	23	23
2	YSH,H,E,F-200	700	505	245	260	240	175	65	46	36	46	36	31	31
3	YSL,H-300	880	505	245	260	280	175	105	52	43	52	43	34	34
2	YSS-200	835	640	326	314	448	278	170	52	43	52	43	34	34
2.5	YSS-250	880	640	326	314	448	278	170	52	43	52	43	34	34
3	YSS-300	960	640	326	314	448	340	108	52	43	52	43	34	34
5	YSS-500	1030	640	326	314	448	356	92	62	45	62	45	45	45

Capacity (ton)		0.5	1.0	2.0	3.0	5.0
Lift Length (m)		5	5	5	5	5
Load Chain (mm)		Ø7.1	Ø7.1	Ø7.1 / Ø10	Ø10	Ø11.2
Single Speed (m/min) 50 (Hz)	YSF	6.7	4.7	---	---	---
	YSE	6.7	4.7	2.3	---	---
	YSH	---	6.7	3.3	2.2	---
	YSS	---	---	6.6	4.3	2.7
Motor Power (kw)	YSF	1.8	1.8	---	---	---
	YSE	1.5	1.5	1.8	---	---
	YSH	---	1.8	1.8	1.8	---
	YSS	---	---	3.7	3.7	3.7
Power Supply (v)	YSF	230	230	---	---	---
	YSE,H,S	415	415	415	415	415
Load Chain and Fall Number	YSF	1	1	---	---	---
	YSE,H,S	1	1	2	2	2
Weight (kg)	YSF	55	55	---	---	---
	YSE,H	50.5	50.5	61	73	---
	YSS	---	---	125	140	153

財源机械五金贸易

CHYE GUAN TRADING

No. 82 & 84, Jalan Suria 2, Taman Malim Jaya, 75250 Melaka.

Tel: 06- 3363480, 06-3363482 Fax: 06-3363480

Email: chyeguan82@gmail.com

LIFTING TOOLS

IHM HYDRAULIC HAND PALLET TRUCK



Model	Capacity (ton)	Fork Dimensions (mm)					
		W1	W2	L1	L2	H1	H2
IHM2500	2.5	550	150	1070	375	200	80
IHM3000	3.0	685	150	1220	375	200	80

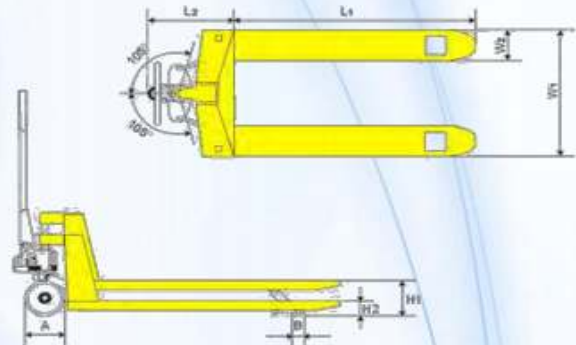

STACKER 1000kg

Model	CYSD1
Capacity (kg)	1000
Lifting Height (mm)	99-1600
Overall Length (mm)	1424
Overall Width (mm)	720
Overall Height (mm)	1980
Fork Length (mm)	900/1150
Fork Width (mm)	133
Fork Outside Distance (mm)	280-680
Lifting Speed (mm/time)	≥22
Descending Speed	Controllable
Center Of Load (mm)	450
Steering Radius (mm)	1250
Front Wheel Diameter (mm)	Ø80
Rear Wheel Diameter (mm)	Ø180
Self Weight (kg)	200

